

## LU0760M200

### 760nm Single Mode Laser Module

# up to 200mW c.w. Operating Power

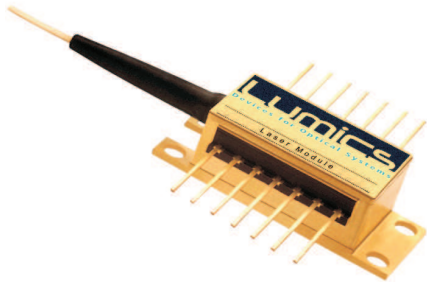

#### Description:

The Lumics LU0760M200 laser diode module contains an optimized GaAs substrate based quantum well high power laser diode. It has been designed for customer specific applications and is available with special FBG's and fibers. The extremely stringent reliability requirements are achieved through our patent pending innovative technology. This includes careful design, exactly defined manufacturing and extensive testing. The qualification contains a set of optoelectronic, thermal and mechanical tests. Each laser diode module is individually serialized for traceability and is shipped with a specified set of test data.

#### Features & Functions:

- Wavelength 760nm
- Up to 200mW c.w. operating power
- Up to 400mW peak power
- Rise time < 2nsec
- Internal TEC temperature stabilisation

#### Options:

- FBG-options
- PM-fiber option
- Low inductive rise fall time < 1ns

#### Benefits:

- All laser welded
- Field proven reliability
- Hermetic sealing
- Telcordia compliant package
- RoHS compliant

#### Applications:

- Analytical Instruments
- Sensor applications
- Pumping
- Printing

#### Module Drawing (dimensions in mm)

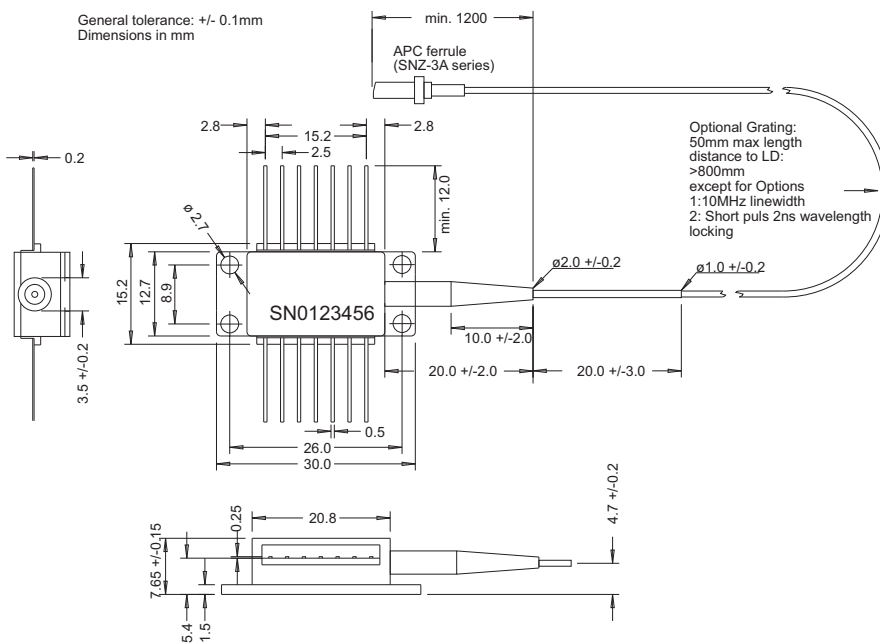

#### Pin Connections

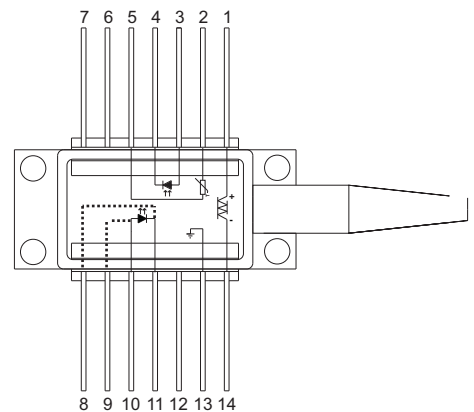

Pin	Function	Pin	Function
1	Cooler (+)	8	(*) LD Cathode (-)
2	Thermistor	9	(*) LD Anode (+)
3	PD Anode (+)	10	LD Anode (+)
4	PD Cathode (-)	11	LD Cathode (-)
5	Thermistor	12	nc
6	nc	13	Case ground
7	nc	14	Cooler (-)

(\*) Optional low inductive

**We manufacture diode lasers.**

## Typical Electrical and Optical Characteristics (at 25°C (T<sub>chip</sub> and T<sub>case</sub>) and Begin of Life (BOL)):

Parameter	Conditions	Symbol	Min	Typ	Max	Unit
Operating power	c.w.	P <sub>op</sub>		200		mW
Operating current	c.w.	I <sub>op</sub>		350	400	mA
Pulsed operating peak power	< 500ns / duty cycle <5%	P <sub>op</sub>		400		mW
Pulsed operating peak current	< 500ns / duty cycle <5%	I <sub>op</sub>			550	mA
Rise and fall time			1		2	nsec
Threshold current		I <sub>th</sub>		90	120	mA
Forward voltage	at I <sub>op</sub>	V <sub>op</sub>		1.95	2.05	V
Peak wavelength λ <sub>peak</sub> (3)	at P <sub>op</sub> , without FBG	λ	755	760	765	nm
Spectral width (FWHM) (3)	at P <sub>op</sub> , without FBG	Δλ	0.05	multiple peaks, 0.1	<1	nm
Spectral width (FWHM) (4)	at P <sub>op</sub> , with FBG only	Δλ	0.05	0.08	0.5	nm
Optical power stability	at I <sub>op</sub> , t = 60 sec	P <sub>op</sub> / t			0.5	%
Polarization extinction ratio (2)	PM fiber version		6	14		dB
Spectral shift with internal temp.	without FBG, internal T <sub>chip</sub>	Δ / T		0.25		nm/ °C
Spectral shift with temp.	FBG Temp.	Δ / T		0.005	0.01	nm/ °C
Spectral shift with current no FBG	(c.w.)			5		nm/A
Spectral shift with current no FBG	(100ns / duty cycle 1%)			1		nm/A
Side mode suppression (3)	at P <sub>op</sub> , with FBG			20		dB
Monitor responsivity		R	1	5	20	μA / mW
Monitor dark current				5	40	nA
TEC current	chip 25°C, case 70°C	I <sub>TEC</sub>		1.1		A
TEC voltage	chip 25°C, case 70°C	V <sub>TEC</sub>		1.9		V
Thermistor resistance	T=25°C	R <sub>th</sub>	9.5	10	10.5	kOhm
Thermistor B constant		B	3850	3950	4050	K
Steinhart-Hart-Equation coefficients	C <sub>1</sub> = 1.1292E-03 / C <sub>2</sub> = 2.3411E-04 / C <sub>3</sub> = 8.7755E-08					
Large signal modulation bandwidth				200		MHz

### Fiber Specifications

Fiber type: single mode HI780 fiber (PM780 on request)

Note:

- 1) Ensure sufficient protection against high energy back reflection pulses from solid state lasers. High energy back reflection damages the diode (for example stimulated Brillouin scattering). Typical damage threshold for 8ns puls @200KHz is 0.05μJ (this level is not covered under warranty).
- 2) Intensity noise of light from modules with PM fiber after polarizer increases with lower polarization extinction ratio (example 6 /10/13 dB can result in intensity noise as high as 50/20/5 %). The intensity noise is sensitive to varying stress (by mechanical and temperature effects) introduced to the PM fiber.
- 3) Without wavelength stabilisation by a fiber bragg grating (FBG) multiple peaks (side modes) around the average wavelength for a specific current in a range of (1-3) nm are observed. The full width half maximum (FWHM) of those peaks can suddenly narrow or broaden. Side mode suppression counts the first side peaks next to the main peak. A peak is defined by significant lower values left and right to this peak.
- 4) With wavelength stabilisation by a fiber bragg grating (FBG) a single peak for a specific current is observed. The full width half maximum (FWHM) of this single peaks is stable over time as long as it is not disturbed by further back reflection from the outgoing optical path.
- 5) Rise and fall time depends on appropriate driver and can be lower than 1ns with the low inductive version.

## Absolute Maximum Ratings

Parameter	Symbol	Min	Max	Unit
Storage temp.	T <sub>max</sub>	-40	85	°C
Operating case temp.	T <sub>op, case</sub>	-20	70	°C
Operating chip temp.	T <sub>op, chip</sub>	20	40	°C
Soldering temp. (max. 10sec)		260		°C
LD forward current (c.w.)	I <sub>op max</sub>		500	mA
LD forward current (Pulse 500ns 5% D.C.)			600	mA
LD reverse voltage	V <sub>R, max</sub>		2	V
Monitor forward current	I <sub>F, PD</sub>		5	mA
Monitor reverse voltage	V <sub>R, PD</sub>		20	V
TEC current	I <sub>TEC</sub>		2.5	A
TEC voltage	V <sub>TEC</sub>		3.2	V
ESD damage (1)			500	V
Fiber pigtail bend radius			25	mm
Maximum transient (<3μs) forward current			0.7	A

(1) A standard human body model (1.5kOhm, 1000pF) is used for ESD thresholds

### Note:

Absolute maximum rating for the laser diode operating current in cw mode may be applied for short period of time only (<10s). Exposure to maximum ratings for extended period of time or exposure above one or more max ratings may cause damage or affect the reliability of the device.

## User Safety

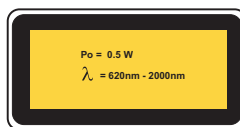

**We manufacture diode lasers.**