



The ModBox-VNA-850nm-30GHz is a wide bandwidth Optical Transmitter designed to extend Vectorial Network Analyzers applications into the optical domain.

When associated with a Vectorial Network Analyzer, they make up a high performance and easy to use test equipment for photoreceivers or any high speed optoelectronic device characterization.

The ModBox-VNA-850nm-30GHz incorporates an 852 nm low noise DBR laser source and a modulation stage based on a large bandwidth LiNbO₃ analog modulator with an automatic bias control circuit.

FEATURES

- Analog modulation up to 40 GHz
- dither-free bias controller
- Low RIN
- High harmonics suppression

APPLICATIONS

- Transmission system test
- Components characterization
- Receiver frequency test
- R&D laboratories

OPTIONS

- C, L, O bands operation
- Multi-Channel

Performance Highlights

Parameter	Min	Typ	Max
Operating wavelength	852 nm		
Modulation format	Analog Modulations		
Frequency	-	30 GHz	40 GHz
Modulated output power	5 mW	8 mW	-

Functional Block Diagram

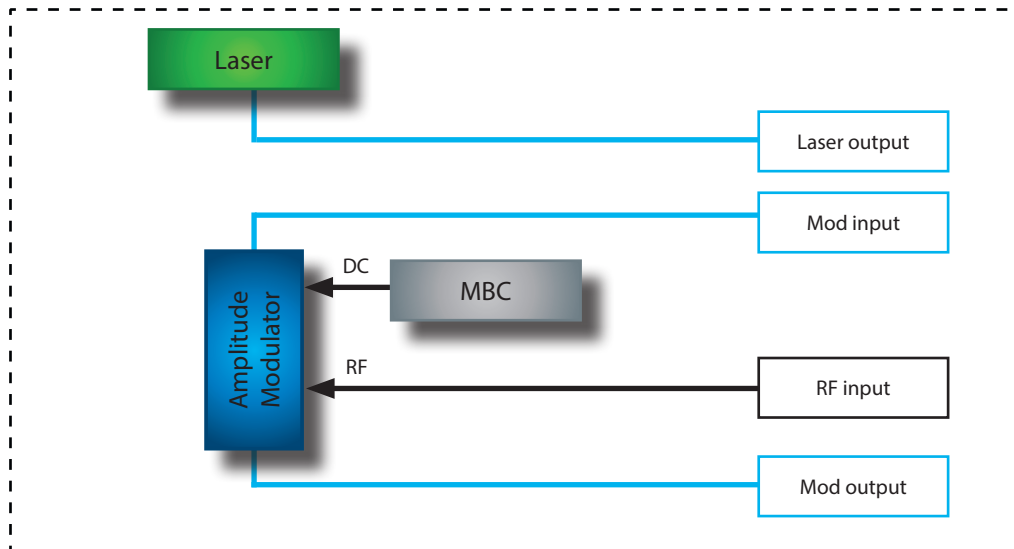

The ModBox-VNA-850m-30GHz features:

- A chirp-free X-cut LiNbO₃ (Lithium Niobate) Mach-Zehnder modulator for very high linearity (high harmonics suppression > 60 dB) with EO-bandwidth > 28 GHz.
- A modulator bias controller. The internal LiNbO₃ modulator is a X-cut device with very low drift. However an automatic bias control circuit is provided to lock the operating point of the modulator at the quadrature point whatever the environmental conditions. The bias control circuit is dither free and therefore does not add any spurious content to the small signal modulation generated by the VNA. It is pre-set for operation in quadrature, in the linear portion of the modulator transfer curve. The system can operate over a large power dynamic range thanks to its software controllable gain parameters)
- An 852 nm low RIN DBR laser. For ease of use, an external patch cord is delivered to connect the laser output to the modulator input optical port. Wavelength and power are tunable through the front panel controls or the ModBox software interface.

Input Electrical Specifications User supplied, not a ModBox specification

Parameter	Symbol	Condition	Min	Typ	Max	Unit
Input electrical termination	-	AC coupled	Single ended			-
Signal type	-	-	Analog			-
Input voltage ⁽¹⁾	V_{IN}	Amplitude Modulation	0.4	0.6	1	mVpp
Impedance matching	Z_{IN-RF}	-	-	50	-	Ω

(1): The ModBox-VNA-850nm-30GHz does not feature an internal RF amplifier. The VNA characterization is usually performed in a “small signal mode”, therefore a RF amplifier is not necessary. Omitting the amplifier allows to obtain a smoother and flatter transfer function.

852 nm DBR Laser Specifications

Parameter	Symbol	Condition	Min	Typ	Max	Unit
Wavelength	λ	By default	852 nm			
Laser type	-	-	DBR			-
Optical output power	-	CW	-	40	50	mW
Spectrum linewidth	$\Delta\lambda$	FWHM	-	2	-	MHz
Optical return loss	ORL	-	30	35	-	dB
Side mode suppression ratio	SMSR	-	30	-	-	dB
Optical output power adjustment	P_{CW}	GUI & front panel knob	1	-	40	mW
Wavelength laser tuning range	-	GUI	-	0.8	1	nm
RIN	RIN	-	-	-	-155	dB/Hz

Output Specifications

Parameter	Symbol	Condition	Min	Typ	Max	Unit
Modulation bandwidth	-	-	-	30 G	40 G	Hz
Modulator insertion loss	IL	At maximum transmission	-	4	5	dB
Modulated output power	-	With connector, @quad bias point	5	8	-	mW
Chirp	α	-	-0.1	0	0.1	-
Optical return loss	ORL	-	-45	-50	-	dB
Electrical return loss	ERL	-	-	-12	-10	dB
Static extinction ratio	ER	-	20	25	-	dB
2 nd harmonic suppression ratio	H_1-H_2	By design	-	-60	-	dB
Bias Control	MBC	Quad mode	Dither-less - Automatic / Manual			

Absolute Maximum Ratings

Parameter	Symbol	Min	Max	Unit
RF input power	EP_{in}	-	28	dBm
Optical input power	OP_{in}	-	16	dBm

Front Panel

Parameter	
Power	Powers the system and lits green when the switch is set on
Rotary knob	Laser power adjustment
Laser Enable / Disable key	Laser switch On / Off
RF input	Single 1.85 mm RF connector
Laser Out	Laser output optical port
Analog Modulation - Mod In / Mod Out	Amplitude modulation input and output optical ports
USB port	Remote control connector (laser wavelength and power, MBC)



Ordering information

ModBox-VNA-850nm-30GHz-XX

VNA = Optical Vectorial Network Analyser extension
 850nm = embeds laser, 852 nm
 30GHz = Analog Modulation up to 30 GHz and beyond
 XX = Output connectors, FA : FC/APC - FC : FC/UPC - SC : SC/UPC

About us

ixBlue Photonics produces specialty optical fibers and Bragg gratings based fiber optics components and provides optical modulation solutions based on the company lithium niobate (LiNbO₃) modulators and RF electronic modules.

ixBlue Photonics serves a wide range of industries: sensing and instruments, defense, telecommunications, space and fiber lasers as well as research laboratories all over the world.

3, rue Sophie Germain
 25 000 Besançon - FRANCE
 Tel. : +33 (0) 381 853 180 - Fax : + 33 (0) 381 811 557

ixblue reserves the right to change, at any time and without notice, the specifications, design, function or form of its products described herein. All statements, specification, technical information related to the products herein are given in good faith and based upon information believed to be reliable and accurate at the moment of printing. However the accuracy and completeness thereof is not guaranteed. No liability is assumed for any inaccuracies and as a result of use of the products. The user must validate all parameters for each application before use and he assumes all risks in connection with the use of the products