



The ModBox-VNA-OBand is a O-Band and wide bandwidth Optical Transmitter designed to extend Vectorial Network Analyzers applications into the optical domain.

When associated with a Vectorial Network Analyzer, they make up a high performance and easy to use test equipment for the characterization of photoreceivers or any high speed optoelectronic device.

The ModBox-VNA-OBand incorporates a 1310 m low low RIN DFB laser source and a modulation stage based on a high bandwidth LiNbO₃ modulator with an automatic bias control circuit.

FEATURES

- Analog modulation up to 40GHz, 65 GHz
- Dither-free bias controller
- Low RIN
- High harmonics suppression

APPLICATIONS

- Transmission system test
- Components characterization
- Receiver frequency test
- R&D laboratories

OPTIONS

- 850 nm, C, O bands operation
- Multi-Channel

Performance Highlights

Parameter	Min	Typ	Max
Operating wavelength	1270 nm	1310 nm	1330 nm
Modulation format	Analog Modulations		
Modulation bandwidth	-	-	40 GHz, 65 GHz
Modulated output power	5 mW	8 mW	-

Functional Block Diagram

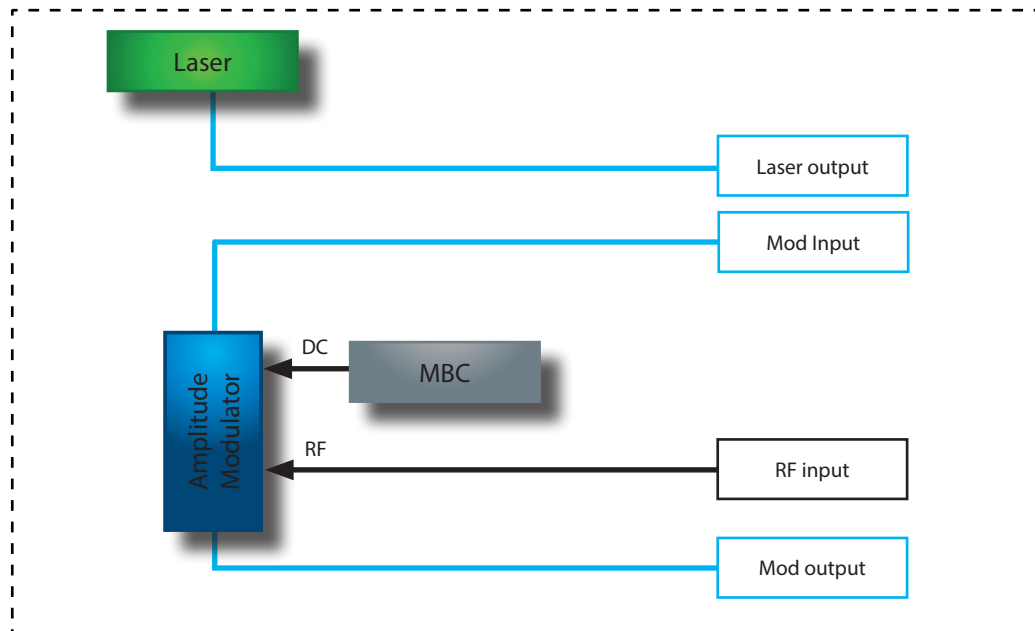

The ModBox-VNA-OBand features:

- A chirp-free X-cut LiNbO₃ (Lithium Niobate) Mach-Zehnder Analog Intensity modulator. It is selected for its high electro-optic bandwidth and flat, low ripple, electrooptic response curve.
- A modulator bias controller. The internal LiNbO₃ modulator is a X-cut device with very low drift. However an automatic bias control circuit is provided to lock the operating point of the modulator at the quadrature point whatever the environmental conditions. The bias control circuit is dither free and therefore does not add any spurious content to the small signal modulation generated by the VNA. It is pre-set for operation in quadrature, in the linear portion of the modulator transfer curve. The system can operate over a large power dynamic range thanks to its software controllable gain parameters).
- An 1310 nm low RIN laser. For ease of use, an external patch cord is delivered to connect the laser output to the modulator input optical port. Wavelength and power are tunable through the front panel controls or the ModBox software interface.

The ModBox-VNA-OBand is controlled from the front panel thanks to the Smart interface with a simple rotary knob and keypad. The Smart manual interface allows for bias control circuit, drivers gain and laser current settings. It comes also with a simple GUI solution, Windows based and implemented through the USB interface of the user PC.

Input Electrical Specifications User supplied, not a ModBox specification

Parameter	Symbol	Condition	Min	Typ	Max	Unit
Input electrical termination	-	AC coupled	Single ended			-
Signal type	-	-	Analog			-
Input voltage ⁽¹⁾	V_{IN}	Amplitude Modulation	0.4	0.6	1	Vpp
Impedance matching	Z_{IN-RF}	-	-	50	-	Ω

(1): The ModBox-VNA-OBand does NOT feature an internal RF amplifier. The VNA characterization is usually performed in a "small signal mode", therefore a RF amplifier is not necessary. Omitting the amplifier allows to obtain a smoother and flatter transfer function.

DFB Lasers Specifications

Parameter	Symbol	Condition	Min	Typ	Max	Unit
Wavelength	λ	CW - By Default	1310			nm
Wavelength	λ	Optional 5 nm wavelength gap	1295 nm, 1300 nm, 1305 nm			-
		Optional 20 nm wavelength gap	1270 nm, 1290 nm, 1330 nm			-
Laser type	-	-	DFB			-
Spectrum linewidth	$\Delta\lambda$	FWHM	-	1	-	MHz
Side mode suppression ratio	SMSR	-	40	55	-	dB

Output Specifications

Parameter	Symbol	Condition	Min	Typ	Max	Unit
Modulation bandwidth	-	ModBox-VNA-OBand-40GHz	-	35	40	GHz
	-	ModBox-VNA-OBand-65GHz	-	60	65	GHz
Modulated output power	-	With internal 1310 nm DFB laser	5	8	-	mW
Optical return loss	ORL	-	-45	-50	-	dB
Electrical return loss	ERL	-	-	-12	-10	dB
Static extinction ratio	ER	-	20	25	-	dB

Absolute Maximum Ratings

Parameter	Symbol	Min	Max	Unit
RF input power	EP_{in}	-	28	dBm
Optical input power	OP_{in}	-	20	dBm

Front Panel

Parameter	
Power	Powers the system and lits green when the switch is set on
LCD	Displays ModBox current status and allows the user to edit parameter in the ModBox menus
Keypad	Allows one to browse through the smart interface menus and edit the system's parameters
System rotary knob	Allows browsing and editing through the ModBox menus
Mod In / Mod Out	Amplitude modulation input and output optical ports
RF input	Single 1.85 mm RF connector
Laser Out	Laser output optical port



Ordering information

ModBox-VNA-OBand-XXGHz-YY

VNA = Optical Vectorial Network Analyser extension
 OBand = Embeds laser, 1310 nm by default
 XX = Analog Modulation bandwidth: 40GHz up to 40 GHz 65 GHz up to 65 GHz
 YY = Output connectors, FA : FC/APC - FC : FC/UPC - SC : SC/UPC

Opt-XX-YY

DFB laser option:
 XX = Optional additional laser - Wavelength in nm
 YY = Input / Output connectors - FA : FC/APC - FC : FC/UPC - SC : SC/UPC

About us

ixBlue Photonics produces specialty optical fibers and Bragg gratings based fiber optics components and provides optical modulation solutions based on the company lithium niobate (LiNbO₃) modulators and RF electronic modules.

ixBlue Photonics serves a wide range of industries: sensing and instruments, defense, telecommunications, space and fiber lasers as well as research laboratories all over the world.